

TORQUEEDO
STARNBERG.GERMANY

**THE LEADER IN
ELECTRIC PROPULSION**

2014





14

DEEP BLUE

for commercial operators and green boaters



26

TRAVEL 503/1003

for tenders, dinghies and daysailers up to 1.5 tons

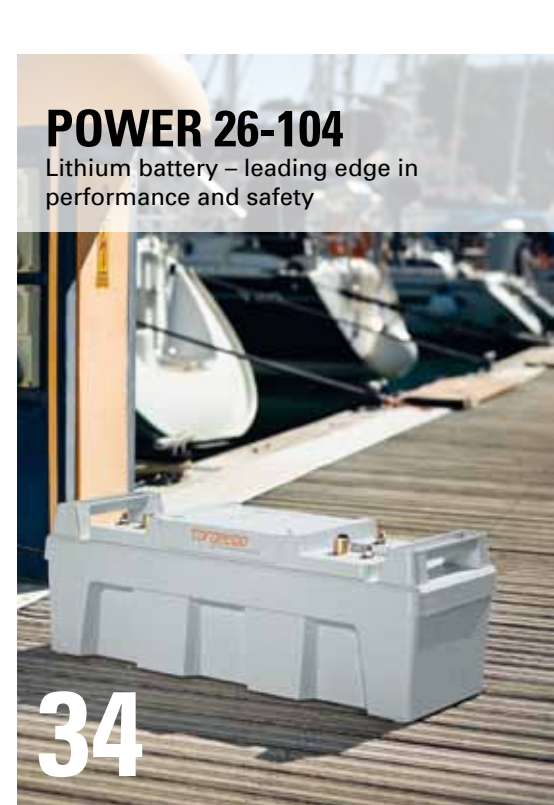

34

POWER 26-104

Lithium battery – leading edge in performance and safety



38

ULTRALIGHT 403

for kayaks and very light boats



30

CRUISE 2.0/4.0

for motorboats and sailboats up to 4 tons

CONTENTS

WHY WE BUILD THE WORLD'S LEADING ELECTRIC PROPULSION SYSTEMS

- 4 Kinder to the natural environment
- 6 Superior propulsive power and superior overall efficiency
- 8 Superior drive train engineering
- 10 Superior battery technology
- 12 Superior convenience

OUR PRODUCTS

- 14 DEEP BLUE
- 24 TORQ TRAC APP **NEW**
- 26 TRAVEL 503 / 1003
- 30 CRUISE 2.0 / 4.0
- 34 POWER 26-104
- 38 ULTRALIGHT 403

DETAILS & SERVICE

- 42 Ordering information
- 44 Technical data
- 46 Contact



NEW DEEP BLUE INBOARD MOTOR

All of the advantages of the Deep Blue system, now for boats with propeller shafts: the Deep Blue 40i and Deep Blue 80i propulsion systems.

NEW DEEP BLUE 40 MODELS

Comparable to a 40 HP gas engine. With less power and less consumption than its big brother.



NEW TORQ TRAC FOR SMARTPHONES

The dashboard for electric motors on your smartphone, with clearly arranged layout, an indication of remaining range overlaid on maps, waypoints and trip logging. Works with all Ultralight, Travel 503/1003 and Cruise models via a simple Bluetooth connection.



KINDER TO THE NATURAL ENVIRONMENT

Electric motors do not pollute the water

- Torqeedo motors don't emit any exhaust gases into the water.
- The water isn't polluted when refueling.
- No oil or unburned fuel is released into the water during operation.

Torqeedo motors leave only a small carbon footprint

It goes without saying that Torqeedo motors don't emit any greenhouse gases while they're in use.

Yet, the emissions during use are only part of the carbon footprint of an outboard. For a proper analysis, all production and logistics steps (of gasoline, electricity, metal, batteries etc.) need to be taken into account. This is called a well-to-wheel analysis, in which Torqeedo motors cut a fine figure:

- Thanks to their lightweight construction, Torqeedo motors have a low carbon footprint in production.
- In operation, it's the superior efficiency that ensures Torqeedo motors protect the environment and climate better than other motors. A Torqeedo Travel can motor more than 10 nautical miles with a battery consumption equivalent to 8 teaspoons of gas. That is not just a range advantage.

No smell, no noise

- Torqeedo products don't produce unpleasant smells during use, transport or storage.
- There's no threat of pollution from leaking oil or gas. That's practical when you want to transport them in the trunk or on the back seat, stow them on board, or when you just want to keep your hands and clothes clean.
- Torqeedo motors aren't completely silent but they are appreciably quieter than comparable gas engines.



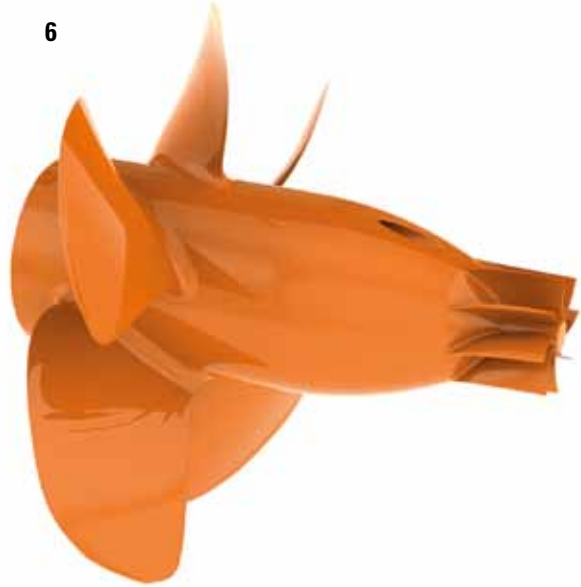

SUPERIOR PROPULSIVE POWER AND SUPERIOR OVERALL EFFICIENCY

ONE HP IS ONE HP. ISN'T IT?

Standardization of power is nothing new, it goes back to James Watt who defined horsepower in the 18th Century to demonstrate the performance of his steam engine. Since then, it's been measured uniformly in HP or, in honor of its inventor, in Watts. And with that, everything should be clear, shouldn't it? Not completely! It depends where and how you measure.

The most meaningful performance indicator of a drive system is propulsive power, which indicates the performance actually delivered by the boat's motor, taking all losses, including propeller losses, into account. This method has been used in commercial shipping for nearly 100 years. For gasoline and conventional electrical outboard

motors the propulsive power is not normally revealed. Instead, less meaningful indicators are used, such as the shaft power, input power or even the static thrust.

That wouldn't be so bad if the differences between the various power ratings were minimal. But they aren't; they're very high. The propulsive power of a gas outboard with 4 HP shaft power, for example, is just 1 HP. The differences between outboards' efficiencies are enormous. We'll shed some light on them.

Input power: A drive's power consumption, which is often used as a performance indicator for electric outboards (current x voltage) and can be expressed in Watts or HP. It can be equally calculated for a gas outboard: gas flow rate x gas energy content.

Shaft power: Power rating of gas outboards, comparable with cars (torque x angular velocity). The rating is expressed in HP or kW, but doesn't take propeller losses into account, which can vary between 30% and 80%.



ADVANTAGE TORQEEDO

Our focus on optimizing the input power and our use of the newest technologies means Torqeedo has the highest overall efficiency on the market. That is, every Torqeedo drive converts its available battery power to propulsive power better than other outboards. This is very important for electric drives because it means more power and range with limited battery capacity.

Overall efficiencies of various outboards

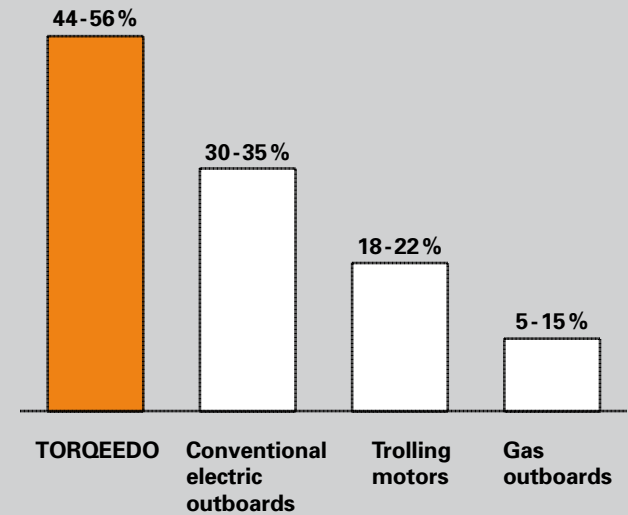

Propulsive power: Performance indicator used by commercial shipping and Torqeedo (thrust x speed). It is expressed in HP or kW and takes all losses into account, including propeller losses, and clearly indicates the actual performance.



SUPERIOR DRIVE TRAIN ENGINEERING

Superior propulsive power and overall efficiency don't just fall out of the sky. They come from inhouse development that works uncompromisingly towards optimizing propulsive power and overall efficiency. Torqeedo uses the newest technology for every component, carefully matching them with each other.

Brushless outrunner motor with rare earth magnets: Since its founding in 2005, Torqeedo has only used brushless, electronically commutated motors.

With traditional electric motors, the rotor is on the inside of the motor, surrounded by the stator; the magnets are on the inside and the coils that generate the alternating field are on the outside. The magnetic field where the torque is generated lies relatively far inside, so this classic design typically produces low torque.

Torqeedo uses outrunners, where the stator with the coils lies on the inside. The magnets are mounted on the rotor, which rotates on the outside the stator. Thanks to this design, the magnetic field that generates the torque can be moved further out, producing to twice the torque of a conventional motor design. Because there is more area on the outside, twice as many magnets can be used. This doubles the torque again.

Plus, by using rare-earth magnets, which have about 5 to 6 times the strength of regular hexaferrites, even more torque is generated. Combining these features gives you motors with more than 20 times the torque of a conventional motor – something of which the propeller takes great advantage.

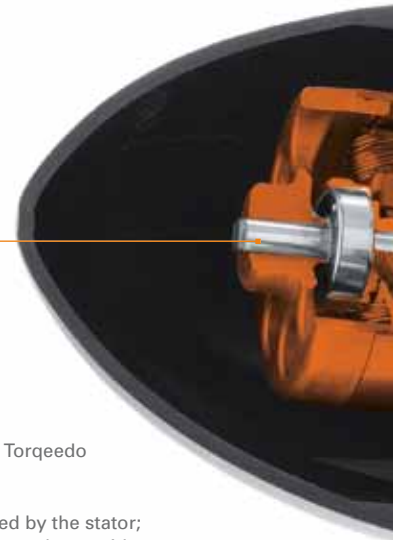

Power electronics: Conventionally, an electric motor's alternating current is switched via sliding contacts – the brushes. Torqeedo motors create the alternating current without contacts via electronic digital switching. Integrated into the drive system, the system switches the current through the coils 35,000 times per second. Benefits of this method: the leading angle of the alternating field is always matched ideally to the load and the speed, which makes it more efficient. Because there are no brushes, efficiency losses are avoided. Plus, while brushes need servicing, brushless motors are maintenance-free.

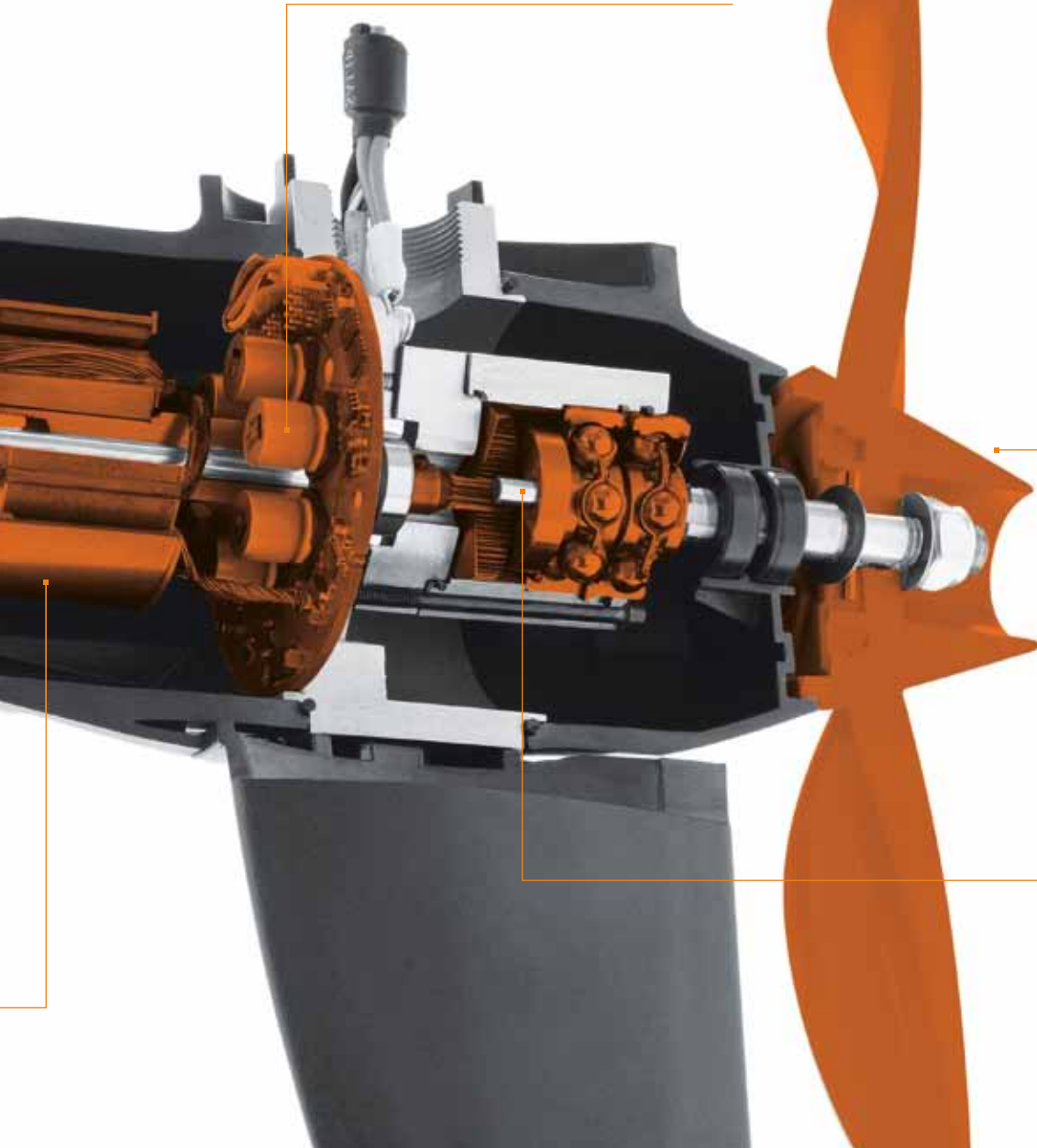

Propeller design: According to conventional wisdom, there are three main characteristics of efficient propellers:

1. Large diameter
2. High pitch
3. Low rotational speed

In other words, motors with high torque can turn efficient propellers; motors with low torque can't. But conventional propeller optimization isn't everything. Many outboard propellers, especially in the low horsepower classes, have more or less a standard shape. Torqeedo propellers look different because they are calculated with the same methods (and, by the way, by the same experts) that are used to calculate propellers for the most advanced commercial ships and submarines.

All propeller parameters – diameter, chord length, pitch, skew, rake, thickness and camber – are calculated in a multidimensional optimization process, over many thousands of iterations.

Planetary gear: Top quality, increases the already high torque level of the motor.

Waterproof connections: All connectors are waterproof to IP67 whether connected or not.



SUPERIOR BATTERY TECHNOLOGY

Lithium-based batteries are the technology of choice for electric mobility applications: they store significantly more energy than other batteries, they deliver their capacity even under high loads – a very important benefit for electric propulsion; they don't lose their charge, work in the cold and have no memory effect. Plus, they deliver more cycles.

For 8 years, Torqeedo has continually led the way in marine lithium battery development. Improving our batteries every year, we have created the most comprehensive protection and safety concept for marine lithium batteries on the market – bringing together performance, safety and ease of use.

Waterproof housing to IP67: Even though submerging the battery should be avoided, all Torqeedo batteries are designed to withstand submersion up to 1 m (3 ft) for at least 30 minutes without damage. The waterproofing of each battery is individually tested prior to delivery.

Battery management system (BMS) with redundant safety: All Torqeedo batteries are protected against overcharge, overcurrent (short-circuit current) and over-temperature. They are constructed according to a redundant safety principle: any component with a safety-critical function is backed up by a redundant component that duplicates the safety function. In addition, Torqeedo BMSs provide detailed information about the battery state. Featuring balancing, deep-discharge protection and deep-sleep modes, the batteries can be switched on or off for safe transport and installation and prevent unintentional discharge.

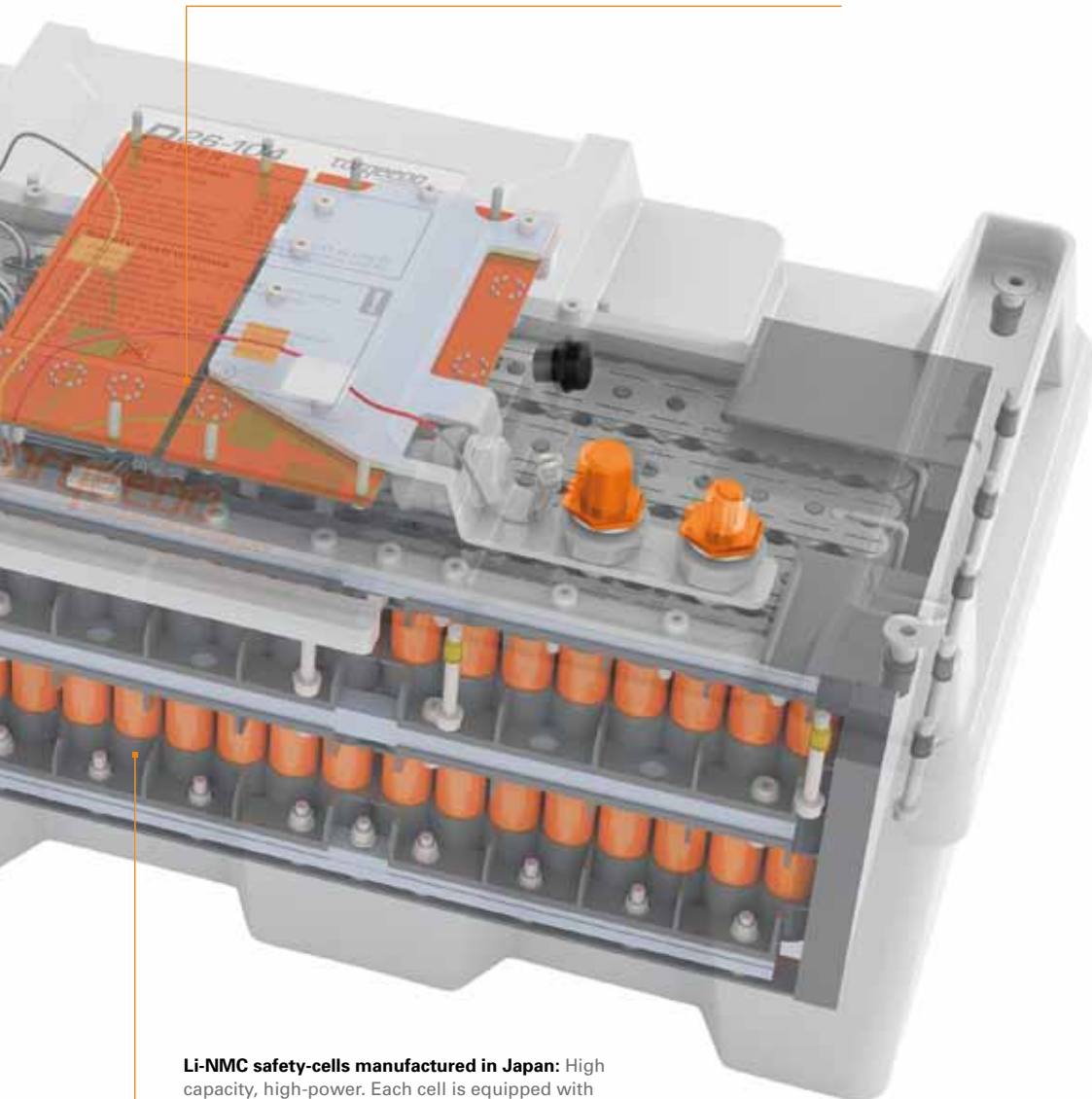

Li-NMC safety-cells manufactured in Japan: High capacity, high-power. Each cell is equipped with three integrated hardware safety mechanisms.

LITHIUM BATTERY SAFETY

Along with performance, safety is a key requirement for lithium batteries. From our point of view, there are **5 requirements that a safe lithium battery must fulfill:**

- 1. Safe battery chemistry,** e.g. LiFePo or LiNMC. These are now commonplace.
- 2. Safe packaging of individual cells:** Torqeedo uses only safety cells, i.e. welded steel cylinders equipped with multiple safety mechanisms. Other packaging – foil-welded cells – offers a reduced level of safety because they don't provide effective protection against internal short circuits (exceptions are foil-welded cells with ceramic separators, which provide safe packaging but are very expensive and very rare).
- 3. Precise and clean production processes at the cell manufacturer level.** Torqeedo only uses cells produced by renowned manufacturers in Japan and the USA.
- 4. Battery-Management-System (BMS) with redundant safety:** Unlike lead-based batteries, lithium batteries generally need a BMS to perform balancing and safety functions. If the BMS fails, it can itself become a safety problem. Which is why, with Torqeedo, all safety-relevant components are duplicated. This is the same method used in the automotive industry, space and medical technology.
- 5. Waterproof IP67:** water inside a lithium battery can cause numerous problems, including corrosion of the BMS and the development of detonating gas. Therefore, lithium batteries onboard must be waterproof.



On-off switch: Turn the outboard on and off at the touch of a button. It couldn't be simpler. After long periods without use, the battery will automatically go into deep-sleep mode to preserve its charge.

Waterproof kill-switch: Stops the motor immediately when pulled. As it works magnetically it does not compromise watertightness.

Waterproof connections: Power-control data from the tiller is transmitted into the control box via a magnet and a sensor. No holes are necessary in the control box. Waterproof design made simple.



SUPERIOR CONVENIENCE

Performance is best enjoyed when it's combined with convenience. Making electric mobility products convenient is a rewarding task because all the system information is available digitally and can be made easily available for the user. Motors and batteries are switched on and off simply at the push of a button. Individual components and complete products are designed to be fully waterproof, and products can be simply and cleanly handled and transported.

Information display: Provides information on battery charge status, speed over ground, power consumption and remaining range. The units displayed can be selected according to your preference (nautical, metric, imperial).

Audible alarm: Just like in a car, the battery management system warns you when the range is getting low. Time to head for the shore or reduce speed to increase range.

Integrated GPS: Part of the battery electronics. GPS data is fed into the on-board information system for the calculation of remaining range.

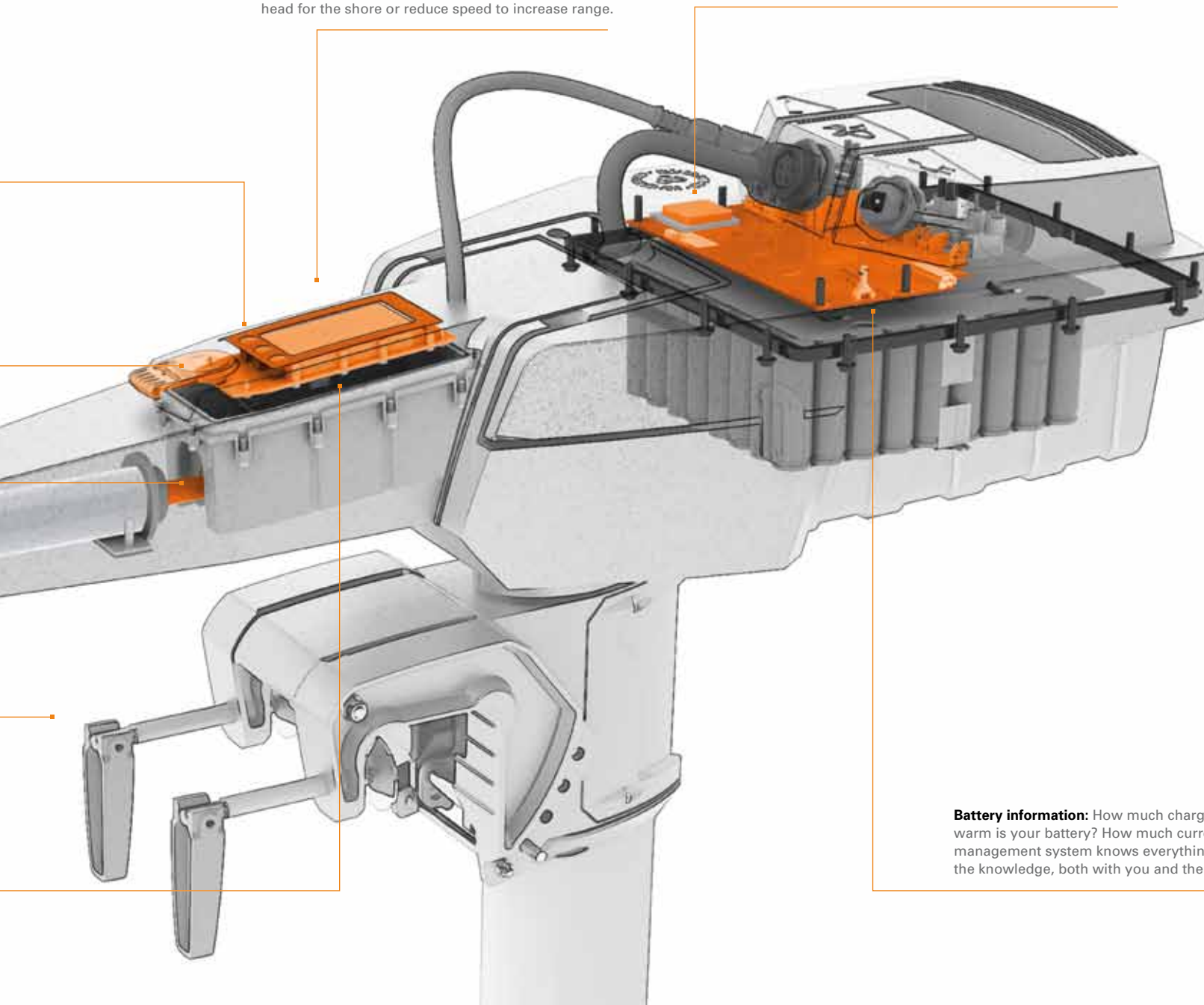

Battery information: How much charge is left in the battery? How warm is your battery? How much current is being delivered? The battery management system knows everything. And the best thing is, it shares the knowledge, both with you and the other components in the system.

DEEP BLUE

FOR COMMERCIAL OPERATORS
AND GREEN BOATERS



40 HP *NEW*

80 HP
equivalent



THE HIGH-POWER SOLUTION

- *The first high-power marine electric propulsion system from serial production*
- *Fully integrated system. Compliant to the relevant standards on system level.*
- *Flat fee boating – economical electric mobility for commercial and frequent users*
- *Superior price / performance ratio for boaters on green lakes*
- *9-year warranty on battery capacity*



DEEP BLUE – FULLY INTEGRATED HIGH TECH SYSTEM

DEEP BLUE 40



The DEEP BLUE System is now available as a 40 HP version.

On-board computer and touchscreen display:

5.7" with 14 different screens. Information about GPS-based range, speed over ground, battery charge status, etc. Can include different destinations and provide range, distance and arrival time information for each. The direction of the destination is shown in the built-in compass.

Electronic remote throttle:

With Power-Trim-and-Tilt (PTT) function, including neutral lock and "kill switch" for the entire system.

12 V battery (not shown): Provides the power needed to turn on the high-voltage battery. Supplies 12 V for the on-board network and is automatically charged from the high-voltage battery.

DEEP BLUE INBOARD MOTOR



The first high-power electric propulsion system from serial production is now available as an inboard version with the same unequalled performance, safety and convenience.

Charger: From the automotive industry. As with all components, waterproof to IP67. Charging capacity can be controlled via the display.

Connection Box: This is where all electrical and signal cables come together. It provides connection for 1-4 batteries and contains a hardware-based safety system. Waterproof to IP66 with water sensor.

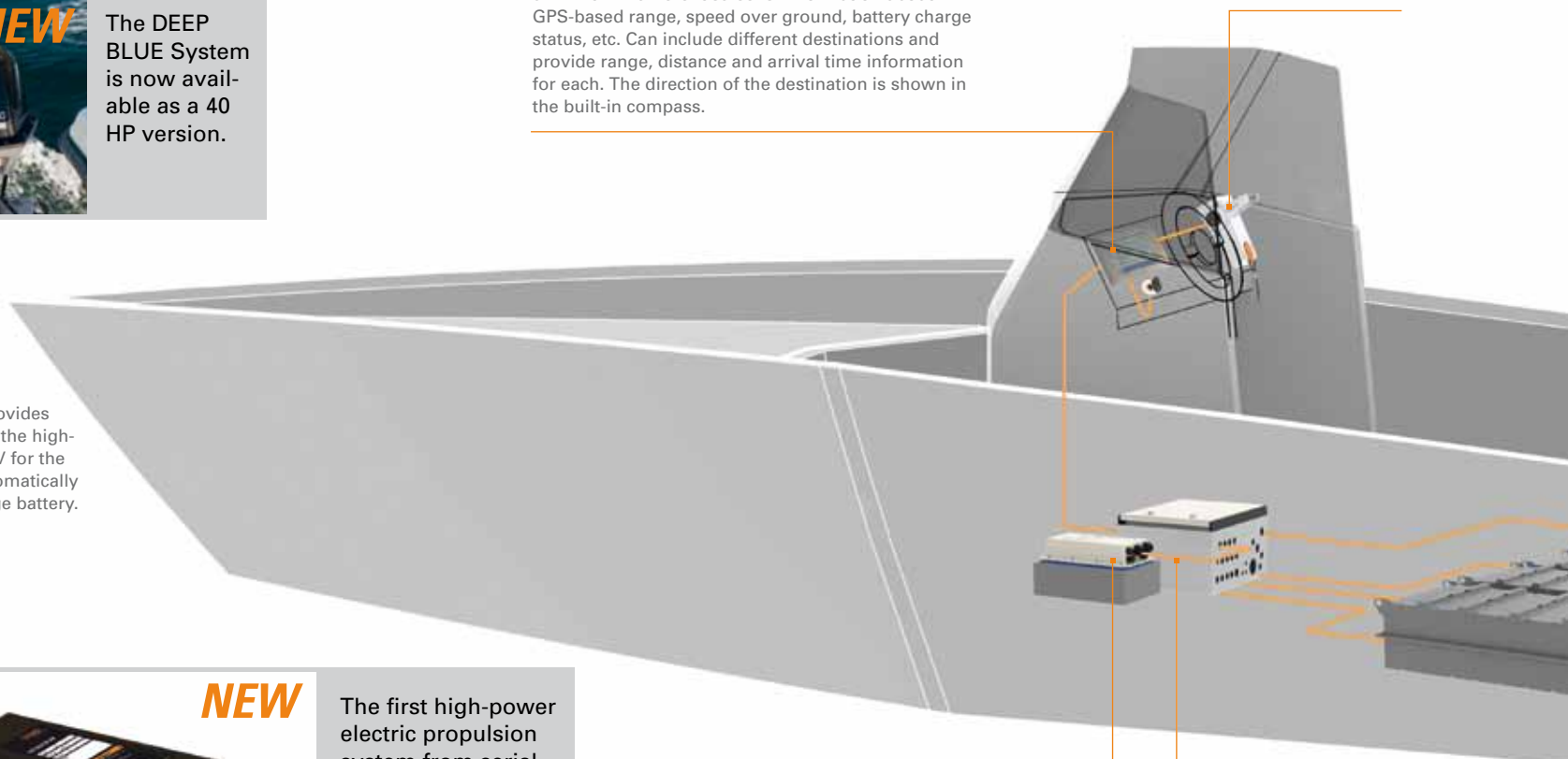



High-voltage battery: From the automotive industry, adapted to the requirements for use in boats, waterproof to IP67. It's completely integrated into the Deep Blue information and safety system. 9-year warranty of 80% of battery capacity.



Motor and motor electronics: Specially developed for the requirements of the Deep Blue vector-controlled brushless motor. Highest efficiency (98%). Suitable for salt water cooling. Waterproof to IP67. With CAN interface NMEA2000 / J1939.

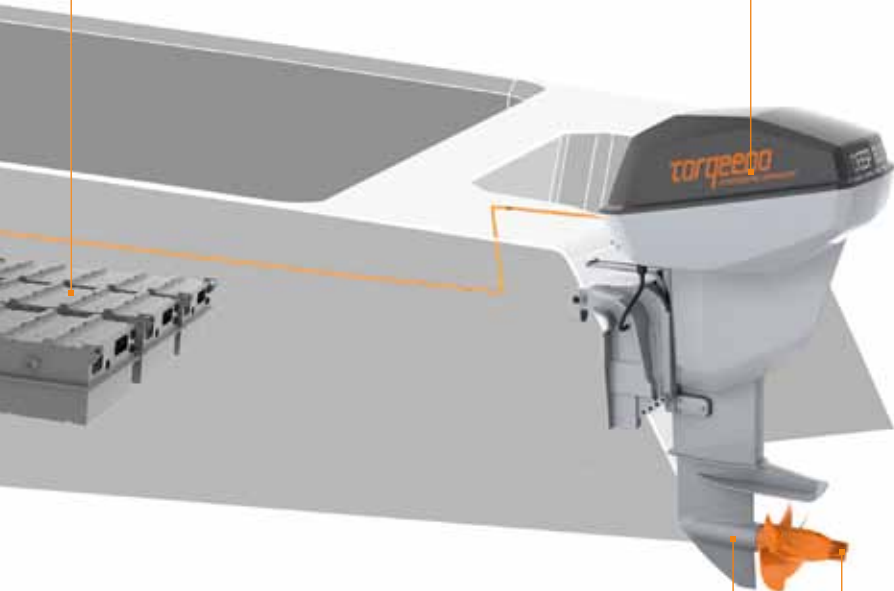

Gearbox: Perfectly matched to fit Deep Blue's requirements. Low maintenance.

Propeller with "Hub-Vortex-Vane" (HVV): Hub-vortex-vanes are derived from commercial ship technology used only by the most modern ships and submarines. Torqeedo is the first company in the boat industry to introduce this technology. The HVV geometry ensures that the propeller hub creates additional propulsive power – instead of just turbulence and losses.



INTEGRATED ENGINEERING OF THE OVERALL SYSTEM IS KEY FOR COMPLYING WITH SAFETY STANDARDS

In the development of high-power propulsion systems, regulatory compliance and safety deserve special attention.

During the years of Deep Blue development, we've applied standard safety concepts from other industries such as the automotive industry - standards previously not attained in powerful electric boat motors.

Electric boat motors, however, also have special challenges that aren't present in other applications. Therefore, taking into account other industries' standards alone is not sufficient. Since we're used to setting standards, we're doing exactly that when it comes to safety.

Here are some examples of Deep Blue's sophisticated safety concept:

Pilot Line: Runs through the shielded cables and all high-voltage connections of the Deep Blue system. It constantly monitors cables for damage and connectors to see that they are plugged in. The pilot line shuts off the system voltage immediately if damaged high-voltage cables or open contacts are detected. Pilot lines are standard safety items for high-voltage uses in other industries – a commonsense precaution that only Torqeedo introduced into boating.



Waterproofing of all components: Components developed for industries other than boatbuilding are seldom waterproof. With conventional drives, only some components are waterproof. In our opinion, high-voltage systems on boats should definitely be totally waterproof. Which is why, at Torqeedo, they are.

IP67

Automotive battery safety: Johnson Controls' lithium batteries are used by various well-known automotive manufacturers. As a result of cooperation between Torqeedo and Johnson Controls, this level of battery technology is available for the first time in the boat industry. Furthermore, the batteries from Johnson Controls underwent additional development to fulfil the specific demands for use in boats and to integrate the battery in Deep Blue's information and safety systems.





Battery venting system: Should the various safety mechanisms in high-voltage batteries fail, safety cells have their own internal safety mechanism: they can exhaust through a valve and vent excess gas and heat in an emergency. The gases emitted in this unlikely situation are hot, toxic, flammable and heavier than air. In electric cars, the battery is positioned so that they simply vent to the street. In boats, the gases released in emergency situations must be led out of the boat so that there is no danger to passengers. Such a venting system is currently only implemented by Torqeedo.



Isolation monitor: Constantly monitors that not only the high-voltage battery but all components associated with the high-voltage supply are isolated from the boat. This is a standard feature with high-voltage machines outside the boat industry but not at all common in powerful electric boats.



Battery damping: On boats, all components are subject to high shock levels that can exceed 12 g. Many components, especially batteries and battery management systems, are not designed to withstand these continual shocks. In cars and buses, batteries are mounted in the shock-absorbed area of the vehicle. In boats, they must have their own damping. So far, only Torqeedo does this.



FLAT FEE BOATING – IT PAYS FOR FREQUENT USERS.

The most significant cost item with the Deep Blue drive system is the battery bank. Thanks to the cooperation between Torqeedo and Johnson Controls, we can offer a long-term warranty on capacity: 80% of the original capacity will be available after 9 years, even if you use it every day.

Are your fuel costs higher than 2,500 USD per year?

If they are, it’s worth checking whether switching to electric motors would meet your speed and range requirements. It might be worth making the change to electric mobility today.

In doing so, you’re protecting yourself from the increases in fuel price that can be expected for many years. Plus, you’re setting an example for ecological sensibility, for consideration of nature and for the future of clean mobility.

DEEP BLUE PRICING AND RUNNING COSTS

	DEEP BLUE 80		DEEP BLUE 40	
OUTBOARD SYSTEM PRICE IN USD (without batteries)	19,999		19,999	
BATTERY AND OPERATING COST				
BATTERY COST				
Number of batteries	2	3	4	1
Capacity in kWh	26	39	52	13
Total battery bank cost USD	32,998	49,497	65,996	16,499
Total cost per year in USD*	3,666	5,500	7,333	1,833
ELECTRICITY COST				
Cost per kWh in USD**	0.112	0.112	0.112	0.112
Single charge (80%) in USD	2.29	3.44	4.59	1.14
150 charges per year (80%) in USD	344	516	688	172
200 charges per year (80%) in USD	459	688	917	229
Total battery and operating cost per year of 150 days usage in USD	3,838	5,844	7,849	2,521
Total battery and operating cost per year of 200 days usage in USD	3,895	5,959	8,021	2,751

* Based on 9 years

** Based on Florida electricity prices, which are ranked 20th in electricity prices in the U.S.

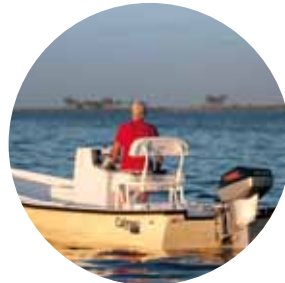

CONFIGURATION

CONTROLS

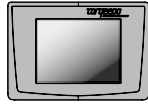

Display

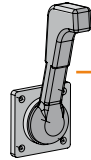

- side-mount throttle
- top-mount throttle
- twin throttle

BATTERIES

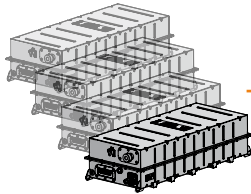

- 1x high-voltage battery
 - 2x high-voltage batteries
 - 3x high-voltage batteries
 - 4x high-voltage batteries
- per motor

CHARGERS

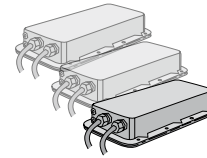

- 1 charger
 - 2 charger
 - 3 charger
- per motor

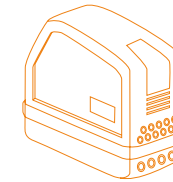

Range extender
Contact us for details

MOTORS

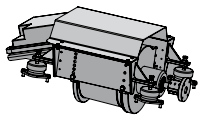

- 40i 2500
- 40i 1200
- 80i 2500
- 80i 1200

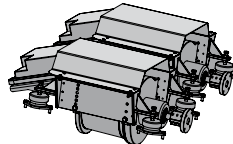

- Twin 40i 2500
- Twin 40i 1200
- Twin 80i 2500
- Twin 80i 1200

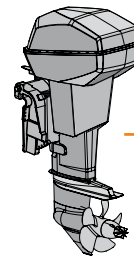

- 40 RL
- 40 RXL
- 80 RL
- 80 RXL

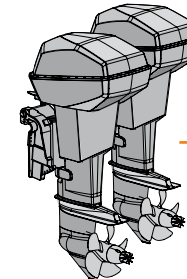

- Twin 40 RL
- Twin 40 RXL
- Twin 80 RL
- Twin 80 RXL

See technical data on page 44 for details.

DISPLAY

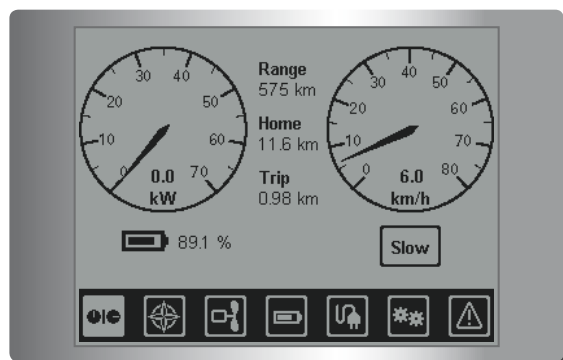

Main screen: Providing information on speed, power consumption, battery charge status, trip logging, remaining range and distance from home or any set waypoint.

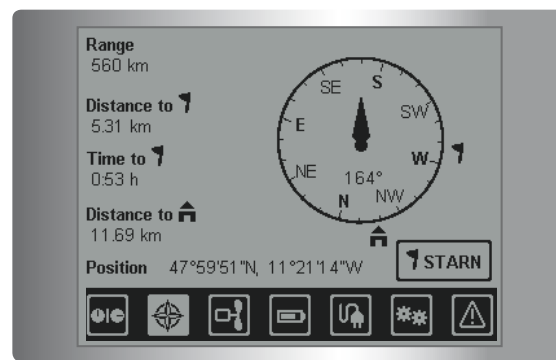

Navigation screen: Displaying information about location, course and range. Provides information for up to 4 waypoints (range, direction, time of arrival).



Other screens: Conveying information about battery life and detailed technical information with regard to the motor, battery and charger, indicators for system status, error messages in plain English as well as setting options for various languages and units.

SPEED, RANGE AND RUNTIME

DEEP BLUE 80 with 2 batteries

	Speed in mph	Range in m	Running time in hours
Slow speed	4.7	24.9 - 74.6	5:20 - 16:00
Full power	22.4 - 33.6	11.2 - 16.8	0:30

DEEP BLUE 40 with 1 battery

	Speed in mph	Range in m	Running time in hours
Slow speed	4.7	23.0 - 37.3	5:00 - 8:00
Full power	19.8 - 27.3	9.9 - 13.7	0:30



TORQ TRAC FOR SMARTPHONES

NEW

THE DASHBOARD FOR ELECTRIC MOTORS ON YOUR SMARTPHONE,
SUITABLE FOR TRAVEL 503/1003, ULTRALIGHT, CRUISE R AND T MODELS

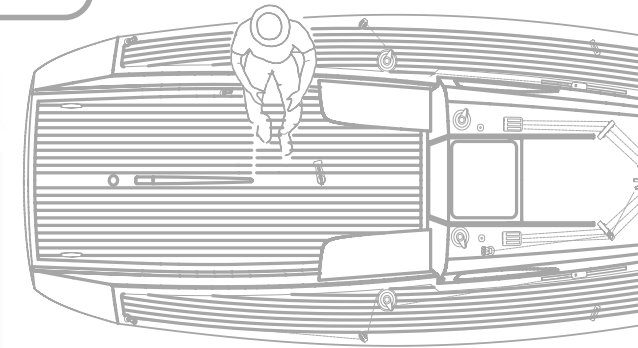
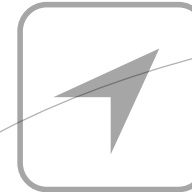

**Improved readability –
in the day or at night**

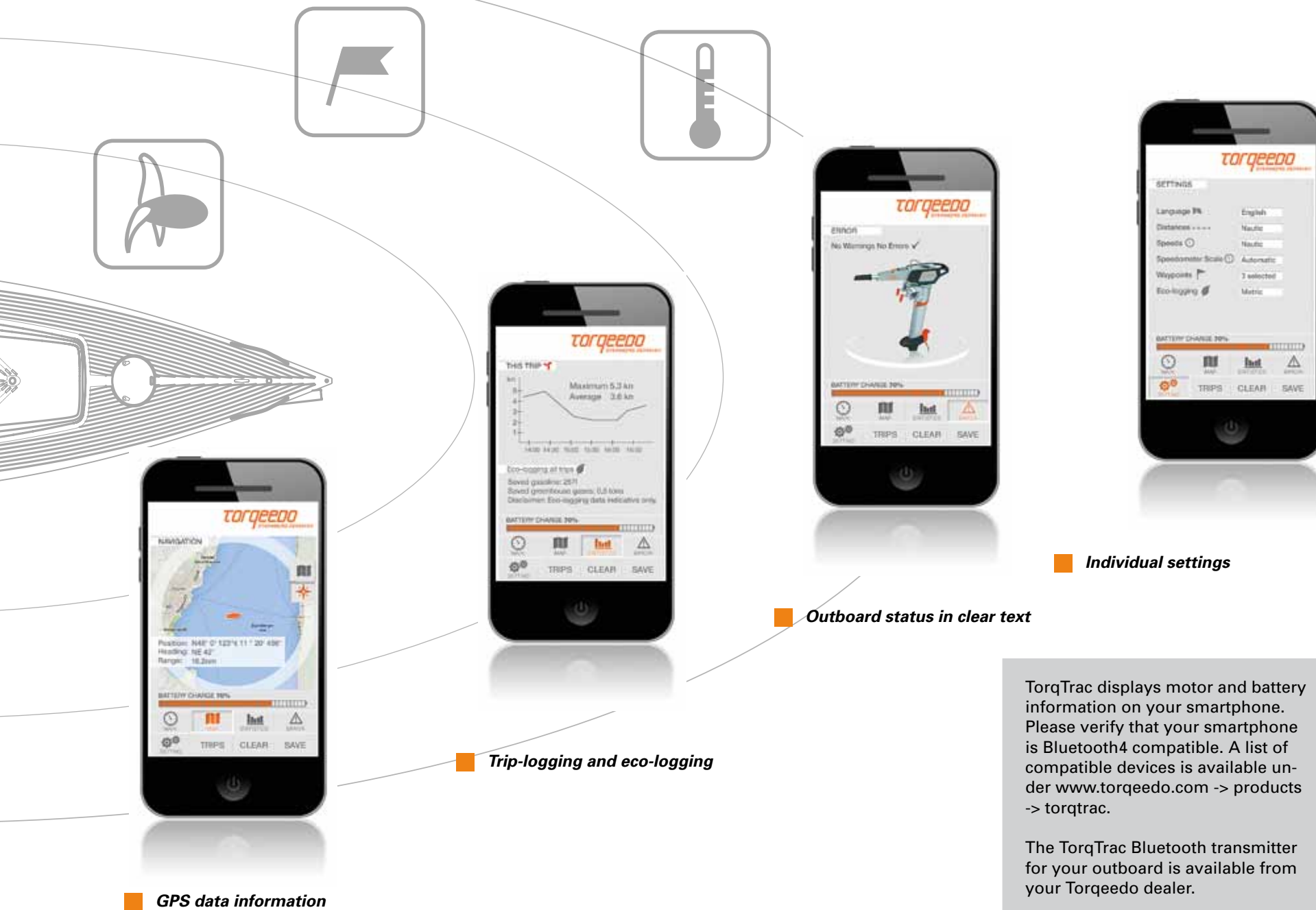

■ **Individual settings**

■ **Outboard status in clear text**

■ **Trip-logging and eco-logging**

■ **GPS data information**

TorqTrac displays motor and battery information on your smartphone. Please verify that your smartphone is Bluetooth4 compatible. A list of compatible devices is available under www.torqeedo.com -> products -> torqtrac.

The TorqTrac Bluetooth transmitter for your outboard is available from your Torqeedo dealer.

TRAVEL 503/1003

FOR TENDERS, DINGHIES
AND DAYSAILERS UP TO 1.5 TONS

1.5 HP

3 HP

equivalent

THE ALL-AROUND SOLUTION

- **Does everything a 1.5/3 HP gas outboard does but is more eco-friendly**

- **Easy to carry.**
Outboard weighs only 19.8 lbs.

- **A clean affair: no spills during use, transport or storage**

- **On-board computer with GPS-based calculation of remaining range**

- **Solar chargeable.**
Underway or when not in use.



Travel along:



The on-board computer uses the tiller or remote throttle to continually display:

85	Battery charge status
113	Remaining range
45	Speed over ground
273	Input power

Audible alarm signal – indicates when the battery charge falls below 30%, then below 20% and, finally, below 10%



High-performance lithium battery with integrated GPS

Long or short shaft available – as you need it. Dimensions on page 44

The socket for the sun: solar charging is possible at any time – even under-way on the water

Power train with highest efficiency for superior performance and range

Batteries

Spare batteries	Travel 503	1144-00
Spare batteries	Travel 1003/503	1145-00



Charging

Charger	included
Spare charger	1127-00
Fast charger <i>New</i>	1131-00
Solar charger 45 W	1130-00



Other Accessories

Travel bags – 2 pieces <i>New</i>	1925-00
Travel battery bag <i>New</i>	1926-00
Motor cable extension	1920-00
Remote throttle (includes 5 ft. and 16 ft. connection cables)	1918-00
Remote throttle extension cable 5 ft.	1921-00
Remote throttle extension cable 16 ft.	1922-00
Replacement propeller v8/p350 (for Travel 503)	1901-00
Replacement propeller v9/p790 (for Travel 1003)	1917-00
Longer tiller arm, 24 in.	1919-00
Torq Trac for smartphones <i>New</i>	1924-00



YOU ASK, WE ANSWER.

Which Travel for which boat?

Both models are suitable for inflatables and other small boats. For sailboats, we recommend the Travel 503 for boats up to 1,650 lbs.; the Travel 1003 easily propels up to 1.5 tons. Both models consume comparable levels of energy at the same speed. The Travel 1003 has a higher maximum power and offers over 60% more battery capacity, providing longer range. Both models are available in long and short shaft versions.

How far can I get on one battery charge?

TRAVEL 503 with integrated battery 320 Wh (29.6 V / 11 Ah)

Tenders, dinghies, yachts up to 750 kg

	Speed in mph	Range in nm (m)	Run time in hours
Slow speed	2.3	approx. 12.8 (14.7)	6:20
Half throttle	3.4	approx. 6.4 (7.4)	2:08
Full throttle	4.6	approx. 2.8 (3.2)	0:42

TRAVEL 1003 with integrated battery 520 Wh (29.6 V / 18 Ah)

Tenders, dinghies, daysailers up to 1.5 tons

	Speed in mph	Range in nm (m)	Run time in hours
Slow speed	2.3	approx. 20.0 (23)	10:30
Half throttle	3.4	approx. 10.5 (12.1)	3:30
Full throttle	5.7	approx. 2.8 (3.2)	0:35

And when the battery is empty, how long does it take before I'm mobile again?

There are various options to choose from. You can, of course, carry a spare battery on board and then you'll be mobile again immediately. Or you can plug in a solar charger (accessory) and charge while you're underway. Or you can charge via the onboard power (an inverter is necessary that converts the onboard supply to 100 – 240 V. Available reasonably priced on the internet). Or connect the battery to an electric socket using the charger provided – that will take approx. 9 hours to fully charge a Travel 503 or approx. 15 hours for a Travel 1003.

New this season: the fast charger. Reduces charging time to 4 hours (Travel 503) and 6 hours (Travel 1003).

Solar charging: How does that work?

It works with the Torqeedo solar charger (accessory) any time the sun is visible, even through a light cloud cover, on the dock when the boat is moored or even when you're underway as long as the solar panel is rolled out flat. Simply plug & charge, without an additional converter. On a sunny day, the output power is around 40 – 45 W, which means the charging time from 0 to 100% for a Travel 503 takes around 8 hours and 13 hours for the Travel 1003.

What is the general life expectancy of lithium batteries?

The life expectancy of lithium batteries in recreational use is, more or less, independent of charging cycles. There is also no "memory effect" which means you can completely charge them after every voyage, regardless of the charge level shown on the display.

In general, a lithium battery can be expected to lose approximately 4% of its capacity per year. If the battery is continuously exposed to high temperatures and fully charged, the process will be accelerated. Using the battery in high temperatures is okay, but store them somewhere cool and shaded.

8 years after the manufacturing date, your battery must be inspected at a Torqeedo Service Center.

Heat – don't high temperatures damage the batteries?

No, because we've built in a temperature protection mode. Before the battery gets too hot, the engine power is automatically reduced – until the temperature is back at a safe level. This function is shown in the display by a thermometer.

What does the integrated battery deliver?

The Travel 503 battery has a capacity of 320 Wh, which means 11 Ah at 29.6 V. For the Travel 1003, it's 520 Wh with 18 Ah at 29.6 V.

What is the warranty?

The Travel has a 2-year warranty from date of purchase.



CRUISE 2.0/4.0

FOR MOTORBOATS AND SAILBOATS UP TO 4 TONS



5 HP

8 HP

equivalent

THE LONG-RANGE SOLUTION

- ***Superior overall efficiency: more range or power from limited battery capacity than any other outboard***
- ***Minimum weight, maximum power***
- ***Available with tiller control (Cruise T) as well as remote throttle and steering (Cruise R).***
- ***On-board computer with GPS-based calculation of remaining range***



Cruise with us:





Connection for standard remote steering

Throttle display – provides information about:

- 85% Battery charge status
- 113 Remaining range
- 4.5 Speed over ground
- 273 Input power



Short or long shaft available – whichever way you need. Dimensions: page 44

Power train with highest efficiency for superior performance and range



Batteries

Power 26-104 – one for the Cruise 2.0 R/T, two for the Cruise 4.0 R/T **2103-00**



Other Accessories

- Throttle cable extension 5 ft. **1921-00**
- Throttle cable extension 16 ft. **1922-00**
- Motor cable extension 6.4 ft. **1204-00**
- Replacement propeller v19/p4000 (fast, efficient, weed repellent) **1916-00**
- Replacement propeller v30/p4000 (for high-speed applications) **1923-00**
- Replacement propeller v8/p350 (lower speed, more thrust) **1901-00**
- Tiller extension, 24 in. **1919-00**
- Twin Cruise extension set (requires 2 Cruise R) **1217-00**
- Torq Trac for smartphones **New 1924-00**

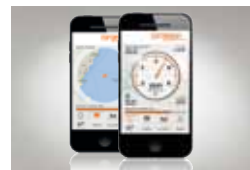

CRUISE 0.8

When long running times are more important than power. For special applications – rental, schools, etc. – the Cruise is available in a reduced power version. For more information: info@torqeedo.com

YOU ASK, WE ANSWER.

Which Cruise for which boat?

All Cruise models are suitable for inflatables and other small boats. For dinghies and sailboats up to 3 tons, we recommend the Cruise 2.0; the Cruise 4.0 easily propels up to 4 tons.

What are the battery options?

The **Cruise 2.0 R/T** requires a battery voltage of 24 V.

If you're looking for a reliable high-end supply, the solution is the Power 26-104. Weight: 53 lbs. Capacity: 2,685 Wh. Alternatively, the Cruise 2.0 can be powered by two lead-gel or AGM batteries. Weight approx. 265 lbs. Capacity: at least 180 Ah.

Because lead-gel or AGM batteries don't deliver high currents very well, the capacity of the battery bank should have some reserve available.

The **Cruise 4.0R/T** requires a battery voltage of 48 V.

Our recommendation: two Power 26-104

Weight of the power battery bank: just under 110 lbs.

Alternative: at least 4 lead-gel or AGM batteries (battery capacity at least 180 Ah)

Weight of the lead-gel or AGM battery bank: approx. 529 lbs.

The **Twin Cruise 2.0R** requires a battery voltage of 2 x 24 V (24 V for each motor).

Torqeedo's solution: two Power 26-104 (one battery per outboard)

Weight of the battery bank: just under 110 lbs.

Alternatively, the Twin Cruise 2.0 R requires at least 4 lead-gel or AGM batteries (battery capacity of at least 180 Ah)

Weight of the lead-gel or AGM battery bank: approx. 529 lbs.

The **Twin Cruise 4.0R** requires a battery voltage of 2 x 48 V (48 V for each motor).

Our recommendation: four Power 26-104 (2 for each outboard)

Weight of the Power battery bank: under 220 lbs.

Alternative: at least 8 lead-gel or AGM batteries

Weight of the lead-gel or AGM battery bank: 1,058 lbs.

How does that all work with the onboard computer?

The onboard computer integrated in the remote throttle of the **Cruise R** or tiller of the **Cruise T** analyzes and combines information from the motor, batteries and GPS. The motor consumption and the GPS speed data are always exact.

When the **Cruise** is powered by the **Power 26-104**, the battery information is equally exact, because both products communicate with each other. Very convenient!

If the **Cruise** is powered by a non-Torqeedo battery, the charge status indicator (and with it, the remaining range indicator) relies on derived estimates from the battery information entered during motor setup.

How far can I get on a complete battery charge?

CRUISE 2.0 with 2 x 12 V / 200 Ah AGM batteries (battery weight approx. 265 lbs.; can also be powered by a Power 26-104)

Dinghies and yachts up to 3 tons

	Speed in mph	Range in nm (m)	Run time in hours
Slow speed	3.1	approx. 27 (31.1)	10:00
Full throttle	6.9	approx. 12 (13.8)	2:00

CRUISE 4.0 with 2 x Power 26-104 (battery weight 110 lbs.; can also be powered by 4 AGM batteries)

Motorboats and sailboats up to 4 tons

	Speed in mph	Range in nm (m)	Run time in hours
Slow speed	3.1	approx. 29 (33.4)	10:45
Full throttle	8.1	approx. 8 (9.2)	1:10

Light boats can reach planing speeds up to 17.4 mph. For some boats, using a twin motor (Twin Cruise 4.0) allows planing speed.

What requirements must my boat fulfill for twin engines – the Twin Cruise?

A **Twin Cruise outboard system** consists of two Cruise models (2.0 R or 4.0 R) and the Twin Cruise extension set, which contains a dual throttle and tie bar. With the tie bar, the two Cruise outboards are connected to the same steering mechanism. The standard Twin Cruise mounting assumes a transom width of at least 30 inches.

What is the warranty?

The **Cruise** has a 2-year warranty from date of purchase.





POWER 26-104
LEADING EDGE IN
PERFORMANCE AND SAFETY

THE POWER SOLUTION

- *State-of-the-art lithium battery: plenty of power with low weight and volume*
- *Superior safety thanks to 5-stage safety system*
- *Outstanding intelligence results in unparalleled convenience – plug-and-play communication with Cruise motors*
- *Attractive pricing – 0.96 USD/Wh*



Charging

Power 26-104 charger **2206-20**
 Solar charger *New* **2207-00**



Other Accessories

On / off switch
 (necessary when Power runs
 without Cruise models) **2304-20**



Data ports for communication: With the Cruise's onboard computer. Plug the cable in, "electronic handshake" and you're done. No major setup requirements.

Water sensor: Knows when the battery is submerged and automatically switches the voltage off at the poles. Avoids potential formation of detonating gas in case water gets into the boat.



Battery management system (BMS) with redundant protection functions: Protects against short-circuits, overloading, deep discharging, reverse polarity, cell and electronic overheating, etc. If electronic components in the BMS fail, the BMS itself can become a safety problem. Therefore, with the Power 26-104 all safety-related functions are doubled, including a pyro fuse that can physically separate the battery's power lines, just like in your car's airbag. Additional features: balancing functionality, an information system and electronic identification.

Isolatable poles: For safe transport and installation. But also practical: isolation prevents unintentional discharge of the battery during long storage periods.

Lithium battery cells: Top quality, exclusively from fully automated Japanese production. Safety cells are used exclusively. Individual battery cells have welded steel cylinders equipped with multiple hardware safety mechanisms.

Technical Data		
General characteristics		
Capacity	2,685 Wh	
Nominal voltage	25.9 V	
Final charging voltage	29.05 V	
Final discharging voltage	21.0 V	
Nominal charge	104 Ah	
Maximum discharge rate (A)	180 A	Safety function, not a starter battery
Maximum discharge rate (W)	4,500 W	
Weight	53.6 lbs.	
Dimensions	22.7 x 8.6 x 10 in.	
Volume	8.5 US gallons	
Battery chemistry	Li NMC	
Benchmark information		
Energy density (Weight)	242.5 Wh/lb	
Energy density (Volume)	22.2 Wh/US gallon	
Price-performance ratio	0.96 USD/Wh	
Power density (Weight)	407.8 W/lb	
Power density (Volume)	37.2 W/US gallon	
Lifetime data		
Cycle lifetime	800 cycles at 100% depth of discharge at 77 °F	Results in ca. 25% capacity loss
Average capacity loss per year	Ca. 4% at 77 °F ambient temperature	
Usage information		
Cell operating temperature	-4° to +140 °F	Battery protects itself
Cell charging temperature	32° to +131 °F	Battery protects itself
Storage temperature	-22° to +131 °F	
Typical storage time at 50% SOC	1 year	
Max. Connections	2S8P or 1S16P	For larger battery banks refer to Torqeedo
Max. quick charge	100 A	Charging time < 1.2 hours
Protection class	IP67	Waterproof, can be submerged up to 1 meter for 30 minutes without damage

Battery composition		
Number of cells	336	
Cell housing	Steel cylinder safety cell	
Capacity per cell	2.25 Ah	
Nominal voltage per cell	3.7 V	
Cell connection	7s48p	
Battery management system and safety		
On-Off switch	Yes	
Cell balancing	Yes	Increases the lifetime of the battery
High current and short circuit protection	Yes	4 level safety cut-off mechanism to protect against short circuit and overcurrent
Deep discharge protection	Yes, cutoff at < 2.7 V per cell, charge protection at < 2 V per cell	
Protection against incorrect charging	Yes	3 protection levels against overcharging
Protection against wrong polarity connection	Yes	
Individual cell voltage monitoring	Yes	
Current interruption device for each cell	Yes	
Safety vent for each cell	Yes	
Poly switch for each cell	Yes	
Cell temperature monitoring	Yes	
PCB temperature monitoring	Yes	
Automatic shutdown in case of submersion	Yes	
Information system		
Interface	RS485	
Electronic battery identification	Yes	Important for connection of multiple batteries into battery banks
Data logging	Yes	Important for warranty information

ULTRALIGHT 403

FOR KAYAKS AND VERY LIGHT BOATS



1 HP
equivalent

THE LIGHTEST SOLUTION

- ***The name says it all – the lightest outboard on the market: 16 lbs. including the battery***
- ***Great performance: maximum speed over 6 mph, range at lower speed up to 25 miles***
- ***Solar chargeable***
- ***Integrated on-board computer with GPS-based calculation of remaining range***



Ultralight underway:





Steering/
tilting/
auto-kickup

Lithium high-performance
battery with integrated GPS

Mounting ball attached to kayak

**Throttle display – provides
information about:**

85%	Battery charge status
1.13	Remaining range
4.5	Speed over ground
273	Input power

Batteries

Replacement battery **1413-00**



Charging

Charger included
Solar charger 45 W **1130-00**



Other Accessories

Motor cable extension	1920-00
Throttle cable extension 5 ft.	1921-00
Throttle cable extension 16 ft.	1922-00
Replacement propeller v10/p350	1912-00
Torq Trac for smartphones <i>New</i>	1924-00

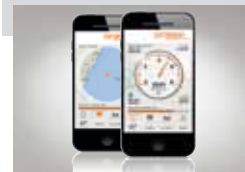

How fast and how far can the Ultralight 403 go?

ULTRALIGHT 403 with integrated battery 320 Wh (29.6 V / 11 Ah)

Fishing kayak, 13.5 ft., 58 lbs.

	Speed in mph	Range in nm (m)	Running time in hours
Slow speed	2.6	19 (21.9)	8:20
Half throttle	3.7	13.5 (15.5)	4:10
Full throttle	5.8	4 (4.6)	0:48

ULTRALIGHT 403 with integrated battery 320 Wh (29.6 V / 11 Ah)

Touring kayak, 15.4 ft., 50.7 lbs.

	Speed in mph	Range in nm (m)	Running time in hours
Slow speed	2.6	22.7 (26.1)	10:00
Half throttle	3.9	14 (16.2)	4:10
Full throttle	6.1	4.2 (4.8)	0:48

What about steering?

The Ultralight 403 can be coupled with your kayak's steering system.

What happens if I capsize?

If the kayak capsizes, the motor stops automatically to prevent injury. The motor only runs when the magnetic pin is placed in the prescribed position on the remote throttle. For safety, the magnetic pin should be attached to the wrist or life jacket. If you should go overboard, the magnetic pin goes with you and the motor stops immediately.

How long does the battery take to charge?

Completely discharged, the battery takes around 12 hours to completely recharge. Our 45 W solar charger – see accessories – can charge on board at any time during the journey as long as the sun is shining.

What is the general life expectancy of lithium batteries?

The life expectancy of lithium batteries in recreational use is, more or less, independent of charging cycles. There is also no "memory effect" which means you can completely charge them after every voyage, regardless of the charge level shown on remote throttle display. In general, a lithium battery can be expected to lose approximately 4% of its capacity per year. If the battery is continuously exposed to high temperatures and fully charged, the process will be accelerated. Using the battery in high temperatures is okay, but store them somewhere cool and shaded.

Eight years after the manufacturing date, your battery must be inspected at a Torqeedo Service Center.

What is the warranty?

The Ultralight has a 2-year warranty from date of purchase.

Which mounting options are available?

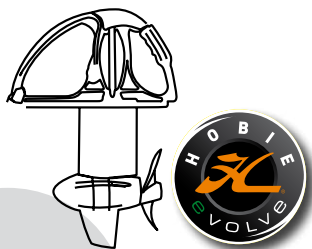

1

Use with Hobie Kayaks: we recommend the Hobie "eVolve" product (available from Hobie dealers).

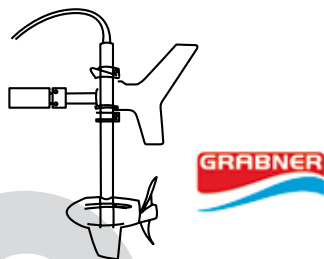

2

Use with Grabner Kayaks: please use the Grabner mounting kit.

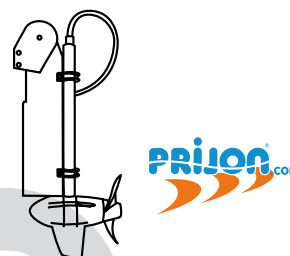

3

Use with Prijon Kayaks: please use the Prijon rudder mounting.

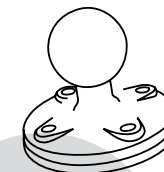

4

All others: using the mounting ball provided, the Ultralight 403 can be mounted on just about any kayak.

ORDERING INFORMATION: MOTORS AND BATTERIES

	Part no.	Product	Description	MSRP in USD
ULTRALIGHT	1403-00	Ultralight 403	Ultralight outboard, 1 HP equivalent, with integrated 320 Wh high-performance lithium battery, including charger, remote throttle, integrated on-board computer with GPS-based range calculation, on/off magnetic key and drybag	1,799
	1413-00	Spare battery Ultralight 403	High-performance lithium battery with integrated GPS receiver, 320 Wh, 29.6 V, 11 Ah	599
	1140-00	Travel 503 S	High-efficiency outboard with integrated 320 Wh high-performance lithium battery, 1.5 HP equivalent, integrated on-board computer with GPS-based range calculation, charger; short shaft version	1,699
TRAVEL	1141-00	Travel 503 L	As part no. 1140-00, but with long shaft	1,699
	1142-00	Travel 1003 S	High-efficiency outboard with integrated 520 Wh high-performance lithium battery, 3 HP equivalent, integrated on-board computer with GPS-based range calculation, charger; short shaft version	1,999
	1143-00	Travel 1003 L	As part no. 1142-00, but with long shaft	1,999
	1144-00	Spare battery Travel 503	High-performance lithium battery with integrated GPS receiver, 320 Wh, 29.6 V, 11 Ah	599
	1145-00	Spare battery Travel 1003/503	High-performance lithium battery with integrated GPS receiver, 520 Wh, 29.6 V, 18 Ah	699
	1220-00	Cruise 2.0 TS	High-efficiency outboard, 5-6 HP equivalent. With tiller control, integrated on-board computer with GPS-based range calculation, 4AWG cable set (9.8 ft.) including fuse and main switch; short shaft version	3,299
CRUISE	1221-00	Cruise 2.0 TL	As part no. 1220-00, but with long shaft	3,349
	1222-00	Cruise 4.0 TS	High-efficiency outboard, 8-9.9 HP equivalent. With tiller control, integrated on-board computer with GPS-based range calculation, 4AWG cable set (9.8 ft.) including fuse and main switch; short shaft version	3,799
	1223-00	Cruise 4.0 TL	As part no. 1222-00, but with long shaft	3,849
	1209-00	Cruise 2.0 RS	High-efficiency outboard, 5-6 HP equivalent. Includes remote steering connector, remote throttle, integrated on-board computer with GPS-based range calculation, 4AWG cable set (9.8 ft.) including fuse and main switch; short shaft version	3,299
	1210-00	Cruise 2.0 RL	As part no. 1209-00, but with long shaft	3,349
	1211-00	Cruise 4.0 RS	High-efficiency outboard, 8-9.9 HP equivalent. Includes remote steering connector, remote throttle, integrated on-board computer with GPS-based range calculation, 4AWG cable set (9.8 ft.) including fuse and main switch, short shaft version	3,799
	1212-00	Cruise 4.0 RL	As part no. 1211-00, but with long shaft	3,849
	1217-00	Twin-Cruise Control Set	For twin applications with Cruise 2.0 R and 4.0 R models, consists of aluminum twin throttle lever with dual info display and 22 inch tie bar for connecting the two motors	799

	Part no.	Product	Description	MSRP in USD
POWER	2103-00	Power 26-104	High-performance lithium battery, 2,685 Wh, nominal voltage 25.9 V, charge 104 Ah, weight 54 lbs., including battery management system with integrated protection against overload, short-circuit, deep-discharge, wrong polarity connection, over-temperature, and submersion, waterproof to IP67	2,599
	2206-20	Charger 350 W for Power 26-104	Charge current 10 A, charges Torqeedo Power 26-104 from 0-100% in max. 11 hours, waterproof to IP65	499
	2304-00	On/off switch for Power 26-104	Switch to activate and deactivate Power 26-104, IP65, with LED indicator displaying on/off status, required if Power 26-104 is used without Cruise outboards	99
	2207-00	Solar charger for Power 26-104	Solar charge controller tailored specifically to the characteristics of Power 26-104. Allows for safe and convenient charging of Power 26-104 from standard photovoltaic modules (PV modules not included in scope of delivery). Integrated MPPT ensures maximum possible power yield from the attached PV modules. Very high efficiency. Output power max 232 watts (8 A, 29.05 V)	449
DEEP BLUE	3201-00	Deep Blue 80 RL	Deep Blue 60 kW outboard system, 80 HP equivalent. Includes: outboard motor, connection box, charger, remote throttle, integrated on-board computer with touchscreen; long shaft version (high-power batteries not included)	19,999
	3202-00	Deep Blue 80 RXL	As part no. 3201-00, but with extra long shaft	19,999
	3203-00	Deep Blue 40 RL	Deep Blue 30 kW outboard system, 40 HP equivalent. Includes: outboard motor, connection box, charger, remote throttle, integrated on-board computer with touchscreen; long shaft version (high-power batteries not included)	19,999
	3204-00	Deep Blue 40 RXL	As part no. 3203-00, but with extra long shaft	19,999
	3301-00	Deep Blue 80i 2500	Deep Blue 60 kW inboard system, 80 HP equivalent (max. 2,500 rpm). Includes: inboard motor with motor electronics, connection box, charger, remote throttle, integrated on-board computer with touchscreen, cable set; long shaft version (high-power batteries, drive shaft and propeller not included)	19,999
	3302-00	Deep Blue 80i 1200	As part no. 3301-00, but with 1,200 rpm propeller speed	19,999
	3303-00	Deep Blue 40i 2500	Deep Blue 30 kW inboard system, 40 HP equivalent (max. 2,500 rpm). Includes: inboard motor with motor electronics, connection box, charger, remote throttle, integrated on-board computer with touchscreen, cable set; long shaft version (high-power batteries, drive shaft and propeller not included)	19,999
	3304-00	Deep Blue 40 i 1200	As part no. 3303-00, but with 1,200 rpm propeller speed	19,999
	4101-00	Deep Blue high-voltage battery	High-power lithium battery, useable energy 12.8 kWh, nominal voltage 345 V	16,499
	4201-00	Charger for Deep Blue high-voltage battery	Additional charger for shorter charging times, 3 kW output power	1,899
3903-00	Top-mount throttle	If chosen, replaces side-mount throttle included in the scope of delivery of the Deep Blue system package.	-	
3904-00	Twin throttle	For Deep Blue twin installations. If chosen, replaces side-mount throttles included in the scopes of delivery of the Deep Blue system packages.	-	

ORDERING INFORMATION: ACCESSORIES

	Part no.	Product	Description	MSRP in USD
ACCESSORIES	1925-00	Travel bags - 2 pieces	Bags for motor and battery of Travel models	169.00
	1926-00	Travel battery bag	Bag for spare battery of Travel models	79.99
	1924-00	Torq Trac App	Smartphone app with improved onboard computer functions. Suitable for Travel 503/1003, Ultralight, Cruise R and Cruise T models. Including data cable with bluetooth module to connect outboard and smartphone.	149.00
CHARGERS	1130-00	Solar panel 45 W	Solar module, can be rolled up, extremely weatherproof, built especially for use on water, plug-and-play connections for watertight charging of the Ultralight and Travel 503/1003 models. Celltype: amorphous silicium.	899.00
	1127-00	Charger for Travel 503, 1003 and Ultralight 403 spare batteries	40 watt charger for power outlets between 100-240 V and 50-60 Hz	69.99
	1131-00	Fast charger for Travel models	85 watt charger for power outlets between 100-240 V and 50-60 Hz	129.00
PROPELLERS & FINS	1912-00	Spare propeller v10/p350	For the Ultralight 402 and 403. (Ø 7.9 in.)	79.99
	1917-00	Spare propeller v9/p790	For the Travel 1003. (Ø 11.5 in.)	79.99
	1915-00	Spare propeller v8/p350	For Cruise models with production year 2009 onwards (serial numbers >5000), slower speed, lower efficiency but higher thrust. (Ø 11.8 in.)	79.99
	1916-00	Spare propeller v19/p4000	For Cruise models with production year 2009 onwards (serial numbers >5000), fast, efficient, weedless. (Ø 11.8 in.)	99.99
	1923-00	Spare propeller v30/p4000	For Cruise models with production year 2009 onwards (serial numbers >5000), for planing applications with lighter boats. (Ø 12.6 in.)	219.00
	1901-00	Spare propeller v8/p350	For the models Travel 401, 801, 503, BaseTravel models, and Cruise models of production years 2006-2008 (serial numbers <5000). (Ø 11.8 in.)	79.99
	9145-00	Fin for travel 503/1003 models	Protects the outboard against running aground	29.99
	9234-00	Fin for Cruise R and T models	Protects the outboard against running aground	29.99

	Part no.	Product	Description	MSRP in USD
THROTTLES & CABLES	1918-00	Remote throttle for Travel 503/1003	Allows installation of Travel 503/1003 models with remote throttle instead of tiller, including integrated display with information about battery status, GPS-based speed and remaining range calculation, including 5 ft. and 16 ft. connection cable between motor and throttle	249.00
	1919-00	Long throttle arm	Longer tiller handle, 24 in. long, for Travel and Cruise T models	59.99
	1920-00	Motor cable extension Travel and Ultralight models	Extension for cable connection between battery and motor for Ultralight 403 and Travel 503/1003 models. Allows for longer distance (6.4 ft.) between battery and motor, with waterproof plug/connectors	59.99
	1204-00	Motor cable extension Cruise models	Extension for Cruise cable set, 6.4 ft. long, with high current plugs	99.99
	1921-00	Throttle cable extension, 5 ft.	Extension cable connection for Travel 503/1003, Ultralight and Cruise T as well as Cruise R models. Allows for longer distance between the throttle/tiller and motor	29.99
	1922-00	Throttle cable extension, 16 ft.	Extension cable connection for Travel 503/1003, Ultralight and Cruise T as well as Cruise R models. Allows for longer distance between tiller or throttle and motor/battery	44.99
	1914-00	Magnet pin	Emergency-stop and immobilizer for Travel, Cruise and Ultralight models	19.99

TECHNICAL DATA

OUTBOARDS < 20 HP

	ULTRALIGHT 403	TRAVEL 503 S/L	TRAVEL 1003 S/L	CRUISE 2.0 TS/TL	CRUISE 4.0 TS/TL	CRUISE 2.0 RS/RL	CRUISE 4.0 RS/RL	TWIN CRUISE 2.0 R	TWIN CRUISE 4.0 R
Input power in watts	400	500	1,000	2,000	4,000	2,000	4,000	4,000	8,000
Propulsive power in watts	180	220	480	1,120	2,240	1,120	2,240	2,240	4,480
Comparable combustion outboards (propulsive power)	1 HP	1.5 HP	3 HP	5 HP	8 HP	5 HP	8 HP	8 HP	15 HP
Comparable combustion outboards (thrust)	2 HP	2 HP	4 HP	6 HP	9.9 HP	6 HP	9.9 HP	12 HP	20 HP
Maximum overall efficiency in %	45	44	48	56	56	56	56	56	56
Static thrust in lbs*	33	40	68	115	189	115	189	230	378
Integrated battery	320 Wh Li-Ion	320 Wh Li-Ion	520 Wh Li-Ion	-	-	-	-	-	-
Nominal voltage	29.6	29.6	29.6	24	48	24	48	24	48
Final charging voltage	33.6	33.6	33.6	-	-	-	-	-	-
Total weight in lbs	16.3	28.4 (S) / 29.7 (L)	29.5 (S) / 30.8 (L)	38.6 (S) / 40.5 (L)	40.3 (S) / 42.3 (L)	35.2 (S) / 37.2 (L)	37.0 (S) / 39.0 (L)	70.4 (S) / 74.4 (L)	74.0 (S) / 78.0 (L)
Motor weight without battery in lbs	9.9	19.6 (S) / 20.9 (L)	19.6 (S) / 20.9 (L)	-	-	-	-	-	-
Weight of integrated battery in lbs	6.4	8.8	9.9	-	-	-	-	-	-
Shaft length in inches	17.7	24.6 (S) / 29.7 (L)	24.6 (S) / 29.7 (L)	24.6 (S) / 29.7 (L)	24.6 (S) / 29.7 (L)	24.6 (S) / 29.7 (L)	24.6 (S) / 29.7 (L)	24.6 (S) / 29.7 (L)	24.6 (S) / 29.7 (L)
Standard propeller (v = speed in km/h at p = power in watts)	v10/p350	v8/p350	v9/p790	v19/p4000	v19/p4000	v19/p4000	v19/p4000	v19/p4000	v19/p4000
Alternative propeller options	-	-	-	v8/p350 v30/p4000	v8/p350 v30/p4000	v8/p350 v30/p4000	v8/p350 v30/p4000	v8/p350 v30/p4000	v8/p350 v30/p4000
Maximum propeller speed in rpm	1,200	700	1,200	1,300	1,300	1,300	1,300	1,300	1,300
Control	Remote throttle	Tiller	Tiller	Tiller	Tiller	Remote throttle	Remote throttle	Remote throttle	Remote throttle
Steering	Provision for connecting to kayak rudder; lockable	360°; lockable	360°; lockable	360°; lockable	360°; lockable	Provision for connecting to standard remote steering; lockable	Provision for connecting to standard remote steering; lockable	Provision for connecting to standard remote steering; lockable	Provision for connecting to standard remote steering; lockable
Tilting device	Manual with grounding protection	Manual with grounding protection	Manual with grounding protection	Manual with grounding protection	Manual with grounding protection	Manual with grounding protection	Manual with grounding protection	Manual with grounding protection	Manual with grounding protection
Trim device	-	Manual, 4-step	Manual, 4-step	Manual, 4-step	Manual, 4-step	Manual, 4-step	Manual, 4-step	Manual, 4-step	Manual, 4-step
Stepless forward/reverse drive	Yes	Yes	Yes	Yes	Yes	Yes	Yes	Yes	Yes
Integrated on-board computer with display	Yes	Yes	Yes	Yes	Yes	Yes	Yes	Yes	Yes

* Torqeedo static thrust measurement is based on internationally accepted ISO standards. Static thrust figures for conventional trolling motors are typically measured differently, which results in higher values. To compare Torqeedo static thrust data with conventional trolling motors, add approximately 50% to the Torqeedo static thrust values.

DEEP BLUE SYSTEM 40/80 HP

	DEEP BLUE 40 RL/RXL	DEEP BLUE 80 RL/RXL	DEEP BLUE 40i 2500/1200	DEEP BLUE 80i 2500/1200
Input power in kW	30.0	60.0	30.0	60.0
Propulsive power in kW	16.2	32.4	> 16.2	> 32.4
Comparable gas outboards (propulsive power)	40 HP	80 HP	40 HP	80 HP
Maximum overall efficiency in %	54	54	> 54	> 54
Useable energy in kWh	12.8	25.6 - 51.2	12.8	25.6 - 51.2
Nominal voltage	345	345	345	345
Final charging voltage	389	389	389	389
Motor weight without battery, including electronics in lbs.	276 (L) / 298 (XL)	276 (L) / 298 (XL)	176	176
Weight of 1 battery in lbs.	328	328	328	328
Total system weight example in lbs.	794 (with 1 battery and 1 charger, long shaft)	1,124 (with 2 batteries and 1 charger, long shaft)	694 (with 1 battery and 1 charger)	1,025 (with 2 batteries and 1 charger)
Shaft length in in.	20" (L) 25" (XL)	20" (L) 25" (XL)	–	–
Standard propeller	v50/p50k	v50/p50k	–	–
Maximum propeller speed in rpm	2,400	2,400	2,500/1,200	2,500/1,200
Steering	Standard remote steering	Standard remote steering	–	–
Tilting device	Electric from throttle	Electric from throttle	–	–
Trim device	Electric from throttle	Electric from throttle	–	–
Integrated on-board computer with touch screen display	Yes	Yes	Yes	Yes

TORQEEDO SERVICE CENTER

Torqueedo Inc.
171 Erick Street, Unit D-2
Crystal Lake, IL 60014
U.S.A.

T +1-815-444-8806
F +1-815-444-8807
usa@torqueedo.com

All other countries

see www.torqueedo.com in the "Service Center" section

Torqueedo North America

T +1-815-444-8806
F +1-815-444-8807
usa@torqueedo.com

Torqueedo Germany, Austria, Switzerland

T +49 (0) 8151-268 67-0
F +49 (0) 8151-268 67-19
info@torqueedo.com

Torqueedo Great Britain/Ireland

T +44 (0) 1502-516 224
F +49 (0) 8151-268 67-19
uk@torqueedo.com

Torqueedo France

T +33 (0) 240-010 604
F +49 (0) 8151-268 67-19
france@torqueedo.com

Torqueedo Spain / Portugal

T +34 609 38 50 44
F +49 (0) 8151-268 67-19
iberia@torqueedo.com

All other countries

Torqueedo GmbH
Friedrichshafener Str. 4a
82205 Gilching, Germany
T +49 (0) 8151-268 67-0
F +49 (0) 8151-268 67-19
info@torqueedo.com

Your Torqueedo dealer

www.torqueedo.com

Goods are delivered exclusively according to our Terms of Sale and Delivery according to Torqueedo's current Terms and Conditions of Business. We reserve the right to make any changes, including pricing, at any time.

